

EVALUATION OF FATIGUE LIFE OF THE CRANKSHAFT

S.R.Deviyaprasanth¹

ME Final year CAD CAM

*Kumaraguru collage of technology
Coimbatore, India.*

Abstract— The crankshaft is one of the critical component on the internal combustion engine. The dynamic analysis has been undergone in this paper under the condition of 4-stroke single cylinder diesel engine. The SOLIDWORKS software is used to create the 3D model of the single cylinder crankshaft. The Finite element analysis method had been carried out in this process to identify the various stress concentration and the critical point of the crankshaft. The preprocessing stage is done through the HYPERMESH software and analyzing and post processing is done through ANSYS software. The dynamic analysis is done through the FEA method which results in the load iteration form applied on the crank pin bearing. The load is applied on the crankshaft based on the engine mounting condition and the stress concentration and the critical point has been found. The stress variation, Torsion and the bending load had been taken in consideration for this analysis. The relationship between the vibration and the frequency had been shown in the harmonic analysis of the crankshaft using this software.

Index Terms— Diesel engine; Crank shaft in Ansys; finite element analysis; stress analysis

I. INTRODUCTION

Crankshaft is a mechanical part able to perform a conversion between reciprocating motion and rotational motion. In a reciprocating engine, it translates reciprocating motion of the piston into rotational motion. In order to do the conversion between two motions, the crankshaft has "crankpins", additional bearing surfaces whose axis is offset from that of the crank, to which the "big ends" of the connecting rods from each cylinder attach.

It is typically connected to a flywheel to reduce the pulsation characteristic of the four-stroke cycle, and sometimes a torsional or vibrational damper at the opposite end, to reduce the torsional vibrations often caused along the length of the crankshaft by the cylinders farthest from the output end acting on the torsional elasticity of the metal.

The fatigue strength of crankshafts is usually increased by using a radius at the ends of each main and crankpin bearing. The radius itself reduces the stress in these critical areas, but since the radius in most cases is rolled, this also leaves some compressive residual stress in the surface, which prevents cracks from forming. The shaft is subjected

to various forces but generally needs to be analyzed in two positions. Firstly, failure may occur at the position of maximum bending; this may be at the centre of the crank or at either end. In such a condition the failure is due to bending and the pressure in the cylinder is maximal. Second, the crank may fail due to twisting, so the conrod needs to be checked for shear at the position of maximal twisting. The pressure at this position is the maximal pressure, but only a fraction of maximal pressure.

A crankshaft is used to convert reciprocating motion of the piston into rotary motion or vice versa. The crankshaft consists of the shaft parts, which revolve in the main bearings, the crank pins to which the big ends of the connecting rod are connected, the crank arms or webs, which connect the crankpins, and the shaft parts. The crankshaft, depending upon the position of crank, may be divided into the following two types.

The crankshaft is the principal member of the crank train or crank assembly, which latter converts the reciprocating motion of the pistons into rotary motion. It is subjected to both torsional and bending stresses, and in modern high-speed, multi-cylinder engines these stresses may be greatly increased by resonance, which not only renders the engine noisy, but also may fracture the shaft. In addition, the crankshaft has both supporting bearings (or main bearings) and crankpin bearings, and all of its bearing surfaces must be sufficiently large so that the unit bearing load cannot become excessive even under the most unfavorable conditions. At high speeds the bearing loads are due in large part to dynamic forces-inertia and centrifugal. Fortunately, loads on main bearings due to centrifugal force can be reduced, and even completely eliminated, by the provision of suitable counterweights. All dynamic forces increase as the square of the speed of rotation. (i.e. $F_{\text{Dynamic}} \uparrow \Rightarrow \text{Speed}^2 \uparrow$).

II. PROBLEM DEFINITION

2. DESIGN CALCULATION FOR CRANKSHAFT

The configuration of the diesel engine for this crankshaft is tabulated in Table I

Table I Specifications of Engine

Capacity	395 cc
Bore x Stroke	86 x 68mm
Compression Ratio	18:1[±0.5%]
Maximum Power	5.52KW @ 3800 rpm
Maximum Torque	16.7 Nm @ 2400 rpm
Maximum gas pressure	25 bar
Maximum Grad ability	20%

2.1 Design of crankshaft when the crank is at an angle of maximum twisting Moment

Force on the Piston $F_p = \text{Area of the bore} \times \text{Max.}$

Combustion pressure $= \pi/4 \times D^2 \times P_{\text{max}} = 14.52 \text{ KN}$

In order to find the thrust in the connecting rod (FQ), we should first find out the angle of inclination of the connecting rod with the line of stroke (i.e. angle θ).

We know that
 $\sin \theta = \sin \theta / (L/R) = \sin 35^\circ / 4$
 which implies $\theta = 8.24^\circ$

We know that thrust in the connecting rod
 $F_Q = F_P / \cos \theta$

From this we have,
 Thrust on the connecting rod $F_Q = 15.12 \text{ KN}$

Thrust on the crank shaft can be split into Tangential component and the radial component.

- 1) Tangential force on the crank shaft, $F_T = F_Q \sin(\theta + \phi) = 11.32 \text{ KN}$
- 2) Radial force on the crank shaft, $F_R = F_Q \cos(\theta + \phi) = 11.21 \text{ KN}$

Reactions at bearings (1 & 2) due to tangential force is given by,
 $H_{T1} = H_{T2} = (F_T \times b_1) / b = 5.02 \text{ KN}$ (Since $b_1 = b_2 = b/2$)

Similarly, Reactions at bearings (1 & 2) due to radial force is given by,
 $H_{R1} = H_{R2} = (F_R \times b_1) / b = 5.34 \text{ KN}$ (Since $b_1 = b_2 = b/2$)

2.1.1 Design of crankpin

Let $d_c =$ Diameter of crankpin in mm.

We know that the bending moment at the centre of the crankpin,

$M_c = H_{R1} \times b_2 = 5.34 \times 86 = 459.24 \text{ KN-mm}$

Twisting moment on the crankpin,
 184.25 KN-mm

From this we have the equivalent twisting moment

$T_e = M_c^2 + T_c^2 = 643.49 \text{ KN-mm}$

We know that equivalent twisting moment (T_e)

$T_e = (\pi/16) \times (d_c)^3 \times \tau$

Shear stress value is limited to 35 N/mm²
 so $d_c = 41.47 \text{ mm}$

Since this value of crankpin diameter ($d_c = 41.47 \text{ mm}$) is less than the when the crank is at top dead centre already calculated value of crankpin dia. ($d_c = 44 \text{ mm}$) therefore, we shall take, $d_c = 44 \text{ mm}$.

Diameter of the crank pin = 44 mm

Design of crank pin against fatigue loading

According to distortion energy theory

The von Mises stress induced in the crank-pin is,
 $M_{ev} = 1007.38 \text{ KN-mm}$

Here, $K_b =$ combined shock and fatigue factor for bending (Take $K_b = 2$)

$K_t =$ combined shock and fatigue factor for torsion (Take $K_t = 1.5$)

$M_{ev} = (\pi/32) \times (d_c)^3 \times \sigma_v$
 $\sigma_v = 114.26 \text{ N/mm}^2$ and also calculated shear stress on the shaft $\tau = 52.23 \text{ N/mm}^2$

RESULTS:-

- Diameter of the crankpin = 44 mm
- Length of the crankpin = 24 mm
- Diameter of the shaft = 41 mm
- Web thickness (both left and right hand) = 23 mm
- Web width (both left and right hand) = 63 mm

III. METHODOLOGY

3.1 Procedure of static Analysis

- 1) First, an assembly in Solid works is prepared for crankshaft and Save as this part as IGES for Exporting into Ansys Workbench Environment. Import .IGES Model in ANSYS Workbench Simulation Module.
- 2) Apply Material for Crank Shaft (Forged steel).

Material Details

- Material Type: - Forged Steel
- Designation: - 42CrMo4
- Yield strength (MPa):- 680
- Ultimate tensile strength (MPa):- 850
- Elongation (%):-13
- Poisson ratio:-0.3

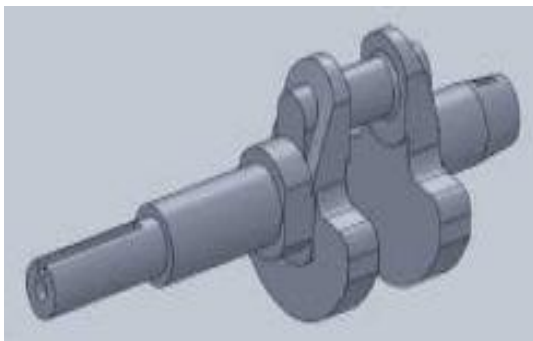

Fig 3.1 Crankshaft In Ansys

3) Mesh the Crankshaft
Mesh Statics:
Type of Element: Tetrahedrons
Number of Nodes: 17119
Number of Elements : 9605

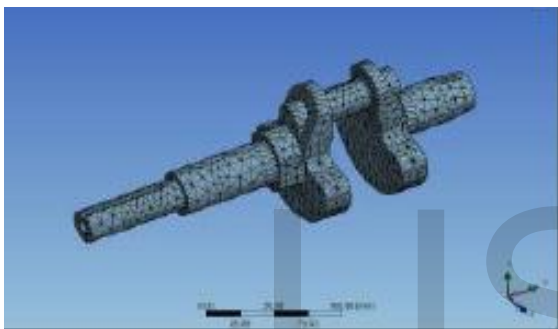

Fig 3.2 Meshed model of Crankshaft

4) Define boundary condition for Analysis
Boundary conditions play an important role in finite element calculation here; I have taken both remote displacements for bearing supports are fixed.

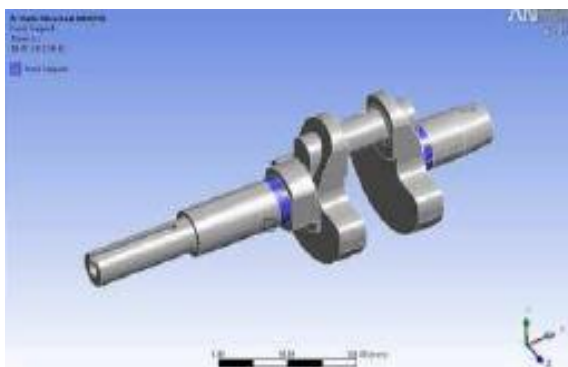

Fig 3.3 Apply Remote Displacement for Bearing Support

5) Define type of Analysis
Type of Analysis:-Static Structural

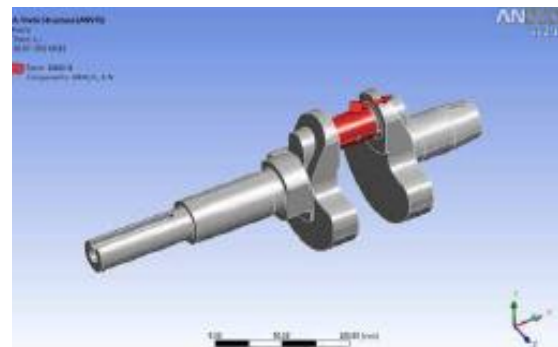

Fig 3.4 Apply Radial Force



Fig 3.5 Apply Tangential Force

6) Run the analysis
7) Get the Results

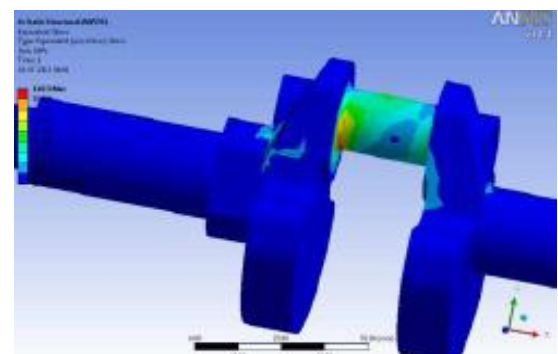

Fig 3.6 Von misses stress

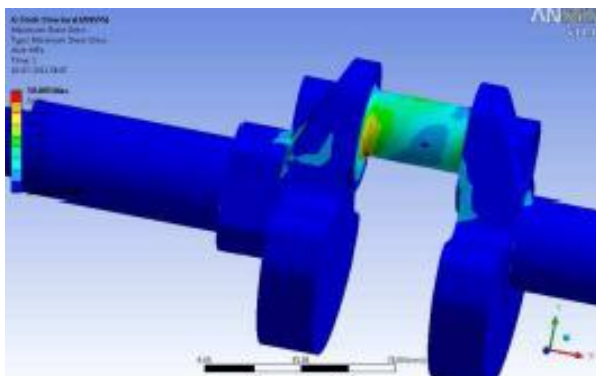

Fig 3.7 Maximum Shear Stress

3.2 Harmonic Analysis of Crankshaft

A technique to determine the steady state response to sinusoidal (harmonic) loads of known frequency.
Run the Analysis

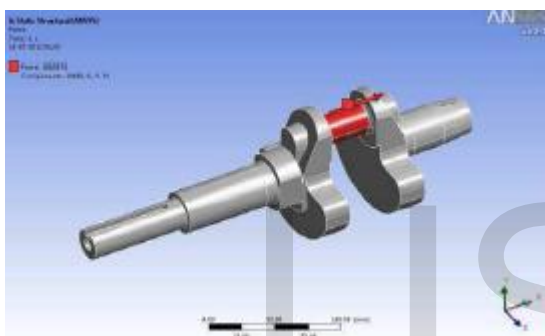

Fig 3.8 Apply Maximum Force at a phase angle of 355

Result of Analysis

Maximum Deformation at a Phase Angle 355

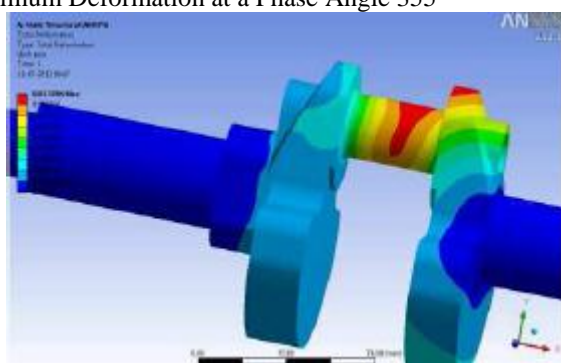

Fig 3.9 Deformation at a phase angle of 355

IV. RESULTS AND CONCLUSION

In this paper, the crankshaft model was created by Solid works 2009 software. Then, the model created by Solid works was imported to ANSYS software.

Result Table:-

S.No	Types of stress	Theoretical	FEA Analysis
1	Von misses stresses (N/mm ²)	114.26	110.3
2	Shear stresses(N/mm ²)	52.23	59.89

Above Results Shows that The maximum deformation appears at the center of crankpin neck surface. The maximum stress appears at the fillets between the crankshaft journal and near the central point Journal.

The Value of Von-Misses Stresses that comes out from the analysis is far less than material yield stress so our design is safe.

V.REFERENCES

1. C.M.Balamurugan, R.Krishnaraj, Dr.M.Sakthivel, K.Kantha,DeepanMarudachalamM.G.,R.Palani.,2011“Computer Aided Modeling and Optimization of Crankshaft,”International Journal of Scientific & Engineering Research Volume 2, Issue 8 ISSN 2229-5518
2. Yu Ding and Xiaobo Li.,2011, “Crankshaft Strength Analysis of a Diesel Engine Using Finite Element Method,” Asia-Pacific Power and Energy Engineering Conference
3. Jian Meng., Yongqi Liu., Ruixiang Liu.,2011,“Finite Element Analysis of 4-Cylinder Diesel Crankshaft,” I.J. Image, Graphics and Signal Processing, 5, 22-29
4. MENG Jian., LIU Yong-qi., LIU Rui-xiang., and ZHENG Bin.,2011,“Intension Analysis of 3-D Finite Element Analysis on 380 diesel crankshaft,” International Conference on Computational and Information Sciences
5. Yu Gongzhi, Yu Hongliang., Duan Shulin., 2011, “Crankshaft Dynamic Strength Analysis for Marine Diesel Engine,” Third International Conference on Measuring Technology and Mechatronics Automation.
6. Gu Yingkui, Zhou Zhibo.,2011,“Strength Analysis of Diesel Engine Crankshaft Based on PRO/E and ANSYS,” Third International Conference on Measuring Technology and Mechatronics Automation
7. Xiaorong Zhou., Ganwei Cai., Zhuan Zhang. Zhongqing Cheng., 2009, “Analysis on Dynamic Characteristics of Internal Combustion Engine Crankshaft System,” International Conference on Measuring Technology and Mechatronics Automation.
8. Farzin H. Montazersadgh and Ali Fatemi., 2007,“Dynamic Load and Stress Analysis of a Crankshaft,” SAE Technical Paper No. 010258, Society of Automotive Engineers
9. JonathanWilliams, FarzinMontazersadgh, Alifatemi, 2007,“FatiguePerformance Comparison And Life Prediction Of Forged Steel And Ductile Cast Iron Crankshafts,”

Published in Proceeding of the 27th Forging Industry Technical Conference in Ft.Worth,Texas

10. Shenoy, P. S. and Fatemi, A., 2006, "Dynamic analysis of loads and stresses in connecting rods,"IMEchE, Journal of Mechanical Engineering Science, Vol. 220, No. 5, pp. 615-624

11. Zoroufi, M. and Fatemi, A.,2005, "A Literature Review on Durability Evaluation of Crankshafts Including Comparisons of Competing Manufacturing Processes and Cost Analysis", 26th Forging Industry Technical Conference, Chicago,

12. Prakash, V., Aprameyan, K., and Shrinivasa, U.,1998, "An FEM Based Approach to Crankshaft Dynamics and Life Estimation," SAE Technical Paper No. 980565, Society of Automotive Engineers

13. Payar, E., Kainz, A., and Fiedler, G. A., 1995,"Fatigue Analysis of Crankshafts Using Nonlinear Transient Simulation Techniques," SAE Technical Paper No. 950709, Society of Automotive Engineers

14. Guagliano, M., Terranova, A., and Vergani, L., 1993,"Theoretical and Experimental Study of the Stress Concentration Factor in Diesel Engine Crankshafts, "Journal of Mechanical Design, Vol. 115, pp. 47-52

15. Henry, J., Topolsky, J., and Abramczuk, M., 1992,"Crankshaft Durability Prediction – A New 3-D Approach," SAE Technical Paper No. 920087, Society of Automotive Engineers

IJSER